

ITEM # _____

MODEL # _____

PROJECT NAME # _____

SIS # _____

AIA # _____



Planetary Mixers XEM-20 21 Qt. Floor Model

603389 (XEM20S) 21 Qt. Floor Model Planetary Mixer
115 V/1p/60Hz

Short Form Specification

Item No. _____

Unit to be Electrolux-Dito 21 Qt. Planetary Mixer with features that include: Body in stainless steel with 18/8 stainless steel bowl. Powerful motor (1.5 kW) with mechanical speed variator. Water protected planetary system. A safety device will automatically stop the machine when the bowl is lowered. Adjustable feet for stability. Supplied with 3 tools: Beater, Dough Hook and Whisk.

Main features

- Power: 2 HP—single phase.
- Variable speed: 25-180 rpm.
- 1.5 kW.
- Red OFF, green ON buttons, and timer.
- Compact design.
- 10 speeds that permit exceptional results.
- The "V" belt speed variator protects the mechanism and the motor against incorrect use.
- Stainless steel bowl - 21 qt. capacities.
- Raising and lowering of the bowl controlled by lever with an automatic locking of the bowl when in the raised position.
- Safety device will automatically stop the machine when the bowl is lowered.
- Powerful motor with high start-up torque.
- Planetary gearing with self-lubricating gears eliminating any risk of leaks.
- Sturdy construction with mechanically welded strong metal frame.
- Delivered with:
 - Beater, Dough Hook, Wire Whisk and Mixing Bowl for 21 qt.
- Dimensions: (LxWxH): 27" x 22.5" x 50.5".
- Approx. shipping weight—235 lbs.
- ETL electrical and sanitation listed/CETL (Canada).
- NEMA # : 5-20P.
- 2 year parts warranty, 1 year labor.

Accessories

- Beater for 21 qt. Mixer.
- Dough Hook for 21 qt. Mixer.
- Wire Whisk for 21 qt. Mixer.
- Mixing Bowl for 21 qt. Mixer.

Optional Accessories

- Beater for 21 qt. Mixer (PNC 653116)
- Dough Hook for 21 qt. Mixer (PNC 653114)
- Wire Whisk for 21 qt. Mixer (PNC 653109)
- Mixing Bowl for 21 qt. Mixer (PNC 653426)
- 21 qt. Bowl Kit with 3 attachments (PNC 653064)
- Reinforced Wire Whisk for 21 qt. Mixer (PNC 653254)
- Stainless Steel tray/shelf for 21/32 qt. Mixer (PNC 653435)



NEMA #: 5-20P

Approval: _____

Front View

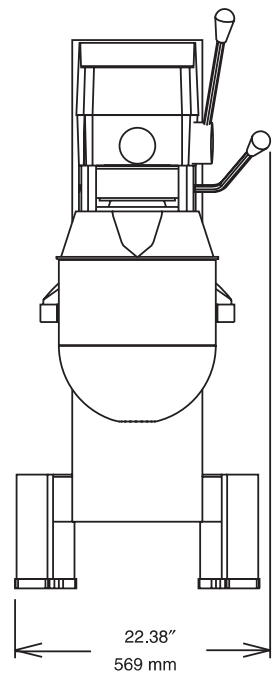

Top View

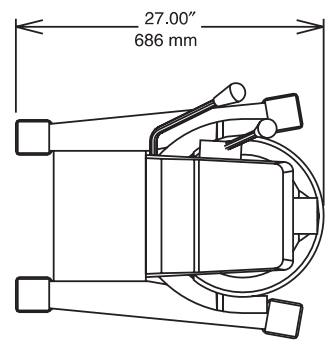

EC = Electrical connection

Side View

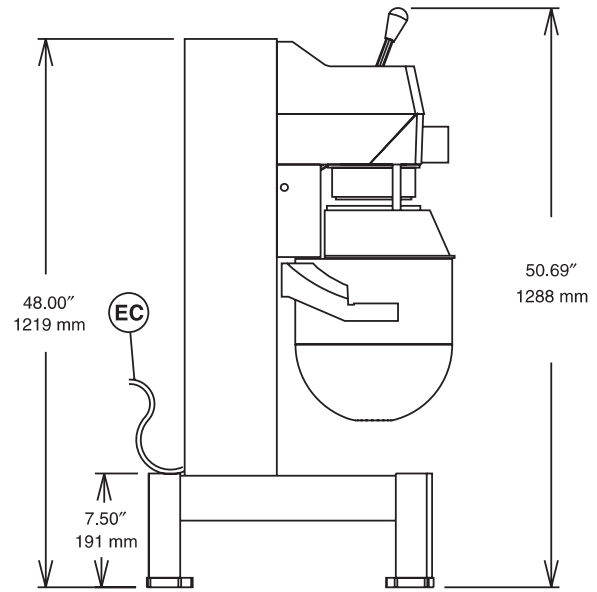

Electric

Supply voltage:
603389 (XEM20S) 115 V/1p/60Hz - 10.2 A

Key Information

Working capacity – lbs. of flour

Shortcrust pastry:	11
Cold water paste:	13
Sweet pastry:	9
Croissant:	11
Brioche:	11
Meat:	22
Potato Puree:	22